

ASSEMBLY INSTRUCTION

Item no.: D219DT

Description: dining table

Thank you for purchasing this quality product .Be sure to check all the packing material carefully for small parts that may have come loose inside the carton during shipment .

step 1:

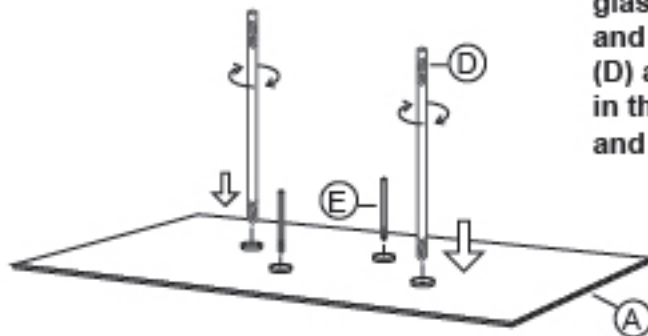

1.Firstly , Put the top glass (A) as picture and fix the long rods (D) and short rods (E) in the metal connector and fasten them well.

step 2:

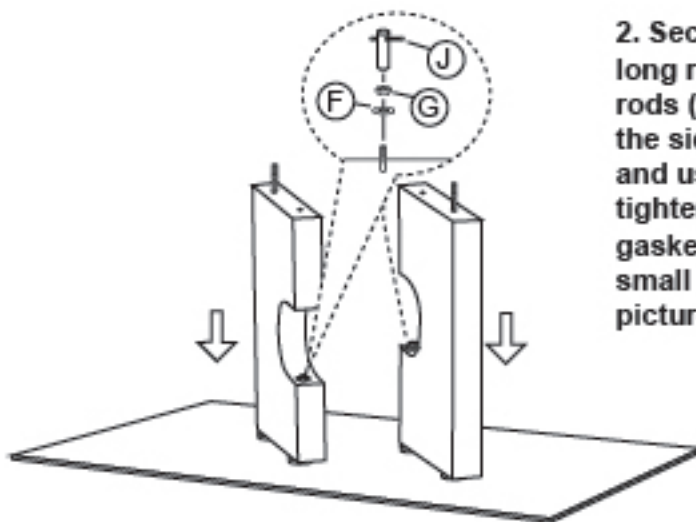

2. Secondly , make the long rods (D) and short rods (E) pass through the side boards (C) and use the tooling (J) tighten the metal gaskets (F) and the small bolts (G) as picture .

step 3:

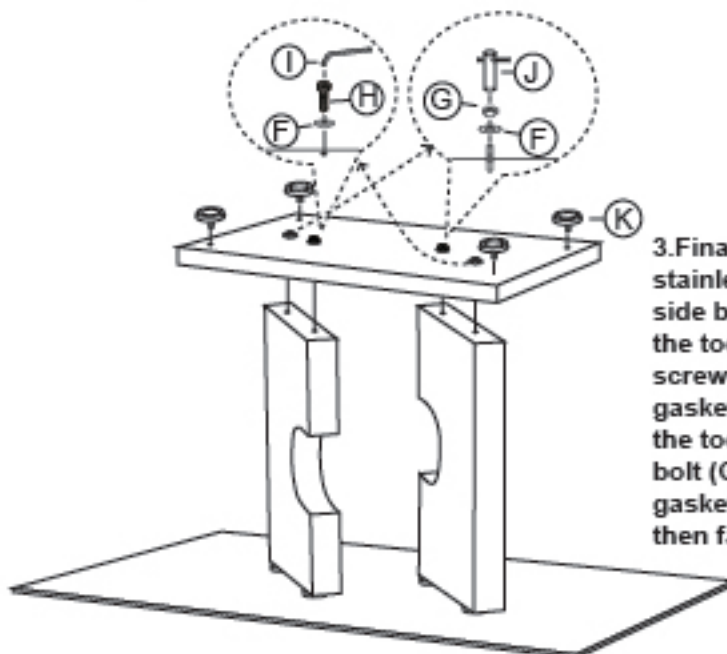

3.Finally ,Put the stainless base (B) on the side board (C) and use the tooling (I) tighten screw (H) and metal gasket (F) meantime use the tooling (J) fasten the bolt (G) and metal gasket (F) as picture then fasten the feet (K) .

PART LIST:

NO.	Description	Diagram	Quantity
A	Top glass		1
B	Stainless Base		1
C	Side board		2

HARDWARE LIST:

NO.	Description	Diagram	Size	Quantity
D	Long Rod		M10x720mm	2
E	short Rod		M10x245mm	2
F	Metal gasket		M10mm	6
G	Bolt		M10mm	4
H	screw		φ 6x40mm	2
I	allen key		M5 mm	1
J	hexagon spanner		M10mm	1
K	Feet		M8 mm	4

step 4:

Finished

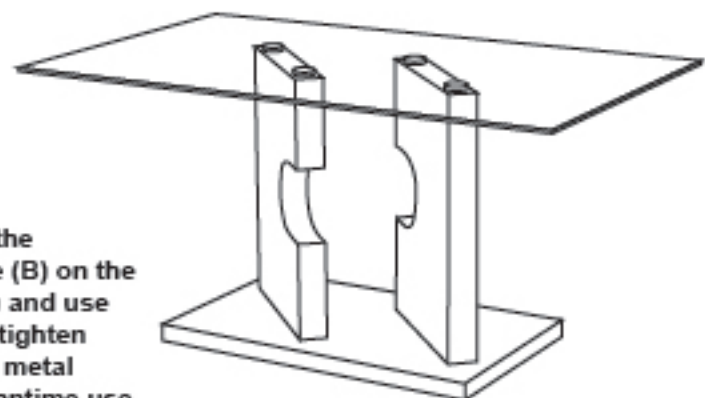

Made in china

ASSEMBLY INSTRUCTION

Model:D41DC

Description:Dining Chair

Thank you for purchasing this quality product. Be sure to check all packing material carefully for small parts that may have come loose inside the carton during shipment.

Step 1:

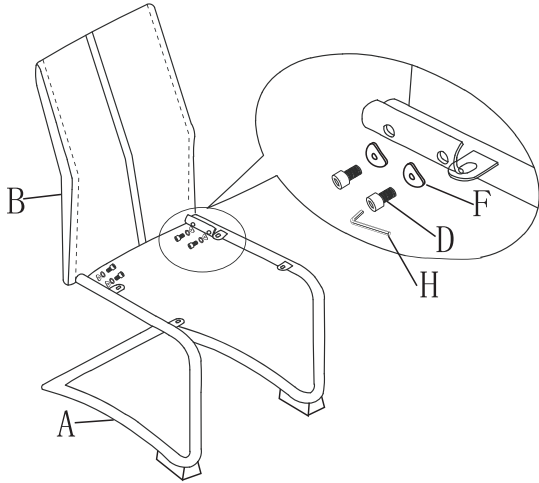

Firstly, fix the backrest with the chair leg but do not fully tighten the bolt(D).

PART LIST:

NO.	Description	Diagram	Quantity
A	Chair leg		1
B	Chair backrest		1
C	Chair seat		1

HARDWARE LIST:

NO.	Description	Diagram	Size	Quantity
D	Bolt		M8X20	4
E	Bolt		M6X16	4
F	Flat washer		M8X22	4
G	Flat washer		M6X16	4
H	Allen key		M6	1
I	Allen key		M4	1

Step 2:

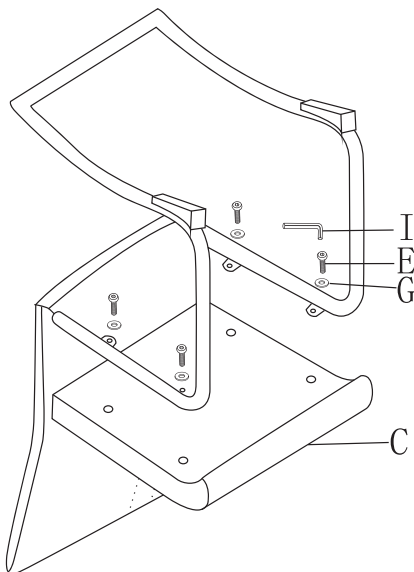

Assemble the chair seat with the chair leg but do not fully tighten the bolt(E).

Finished

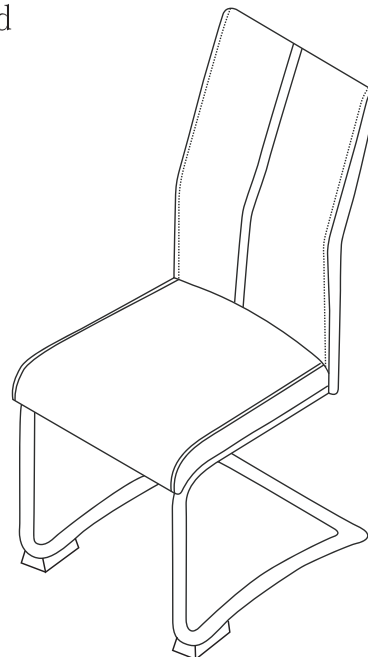

Finally, lean the chair with extra care and tighten the bolt.(D&E).

Made In China