

# Assembly Instruction

Model No : ASPEN 196 LED HEADBOARD

Thank you for purchasing this quality product.  
Please check all packing material carefully which may have come loose inside the carton during shipment.

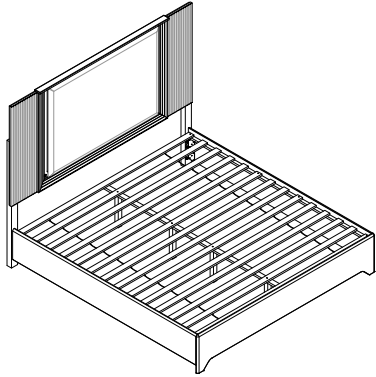

## HARDWARE LIST



No	Description	Qty
A	Circuit Wire 	1pc
B	Prong Connecting Wire 	1pair
C	Power Wall Adaptor 12V-2A 	

DIAGRAM FIGURE 1  
Completed diagram for your reference



**Step : 1**

Please connect each end of Part B into the bottom left facing and right facing circular 3 prong connector. Each end of part B will need to be connected to prong connector #1(top prong) and prong connector #3(bottom prong) as shown in the diagram.

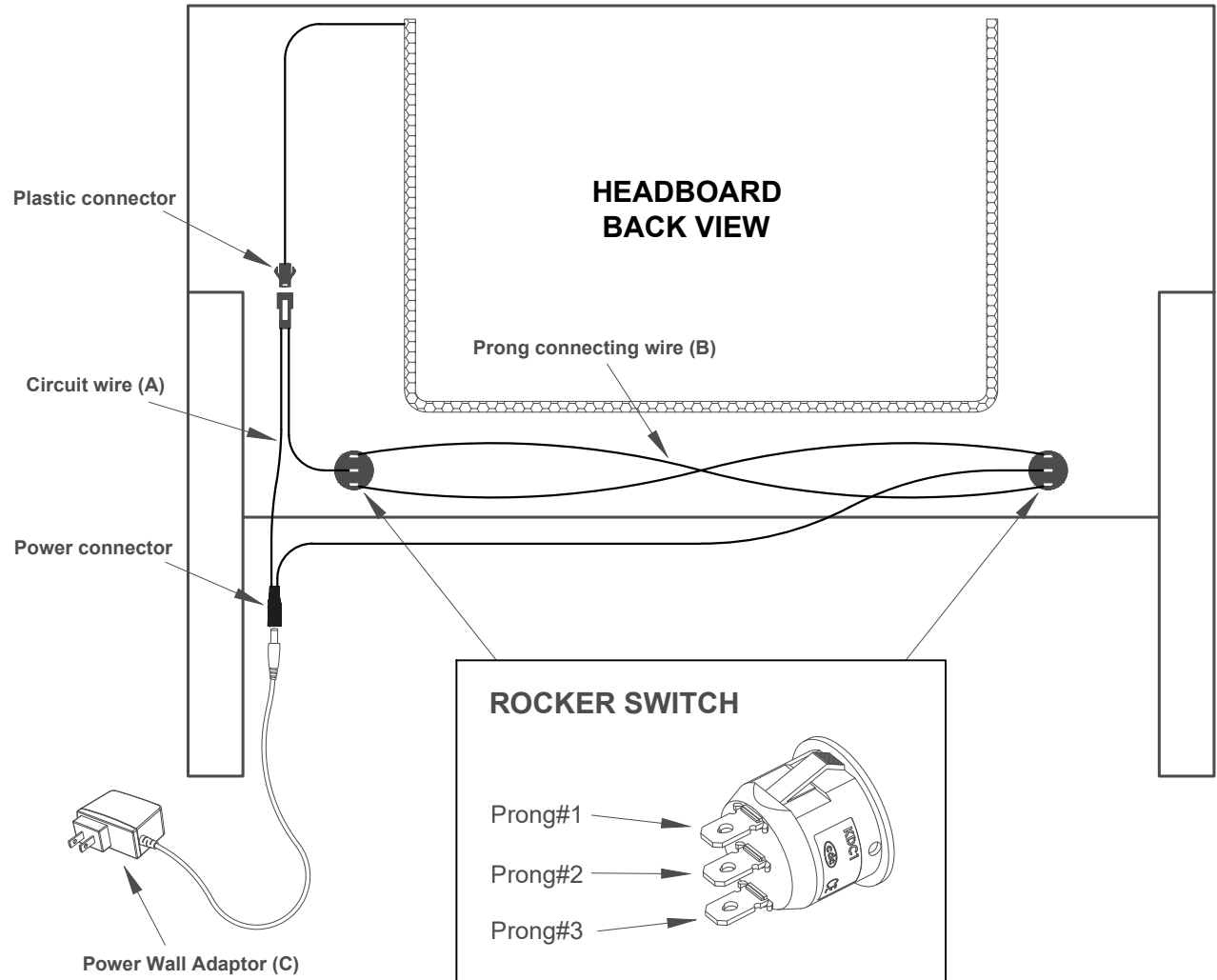
**Part B**



**PLEASE REFER TO PAGE 1 DIAGRAM FIGURE 1 FOR COMPLETED INSTALLATION GUIDE**

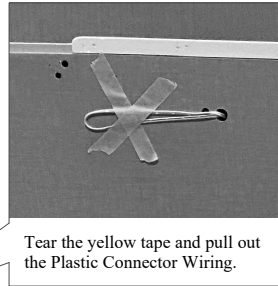

Tear the yellow tape and pull out the Plastic Connector Wiring.

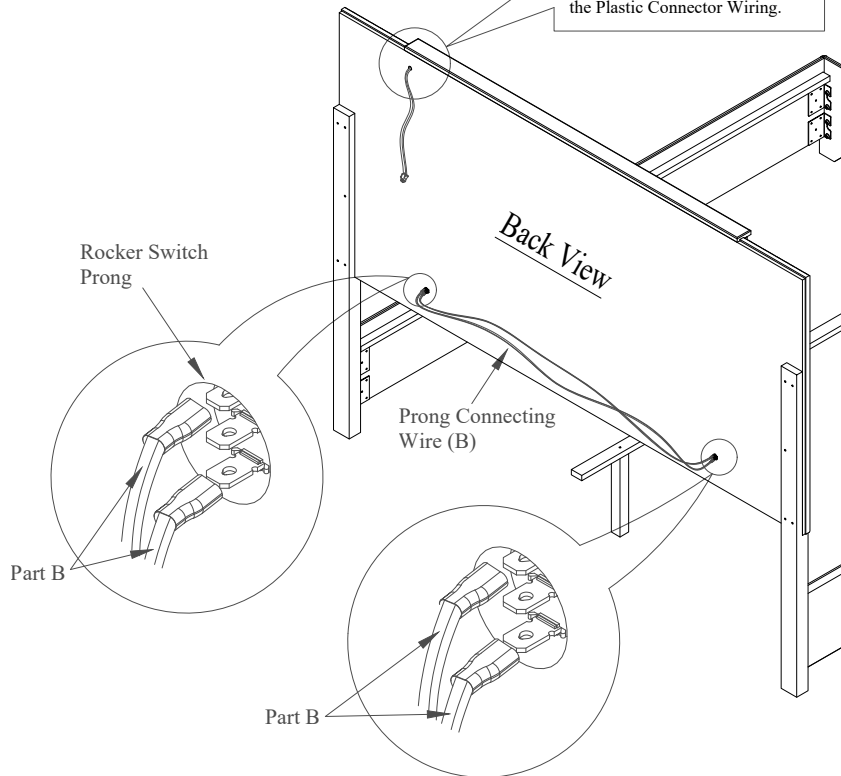

**Part A**

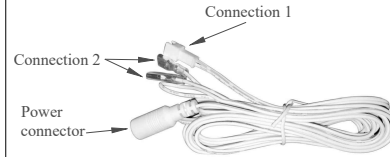

**PLEASE REFER TO PAGE 1 DIAGRAM FIGURE 1 FOR COMPLETED INSTALLATION GUIDE**

Power Wall Adaptor

**Step : 4**

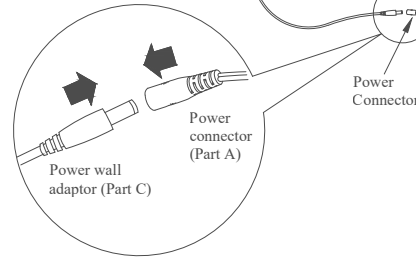

**Step : 3**

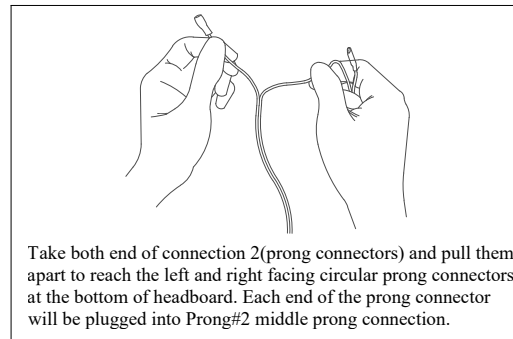

**Step : 2**

Take connection 1 and clip it together with the plastic connector that is pre-installed at the top of the headboard.

