

LIFTMAN™ FOLD – Offshore Rated Personnel Lift



KEY FEATURES

- ATEX approved
- Manual steering
- Twin wheels as option
- Delivered ready-to-use
- Outdoor and indoor use
- Controls and compressed air outlet inside cage
- Entirely pneumatically operated
- Occupies a minimum of floor space
- Sharp turning circle for easy access



| | |
|-----------------------|---|
| Construction | Welded Steel |
| Finish | RAL 1023 |
| Payload | 140 kg (1 person plus equipment) |
| Controls | In cage: Up/Down lever. Manual steering and driving, by using handle (push/pull). At ground Level: Emergency lowering |
| Air Supply | 6.0 - 8.0 bar. 350 litres per minute supplied via a hose. A compressed air outlet for air tools is provided in the cage together with a pressure regulator and gauge. An optional compressed air container (300 bar) can be used in locations where compressed air is not available (approx.15 up-down operations). |
| Key Dimensions | <ul style="list-style-type: none"> • Lifting height: 2 730 mm • Lifting height: 1 670 mm (with mast folded) • Mast height: 3 140 mm • Mast height: 2 050 mm (folded) • Width: 1 250 mm (outriggers out) • Width x Depth: 1 575 x 1 250 mm (folded mast & outriggers out) • Width x Depth: 1 585 x 850 mm (folded mast & outriggers in) • Cage size: 800 mm x 600 mm |
| Installation | The LIFTMAN™ requires only a suitable air supply and a reasonably flat floor to operate. |
| Net Weight | 470 kg. |
| Drawings | |

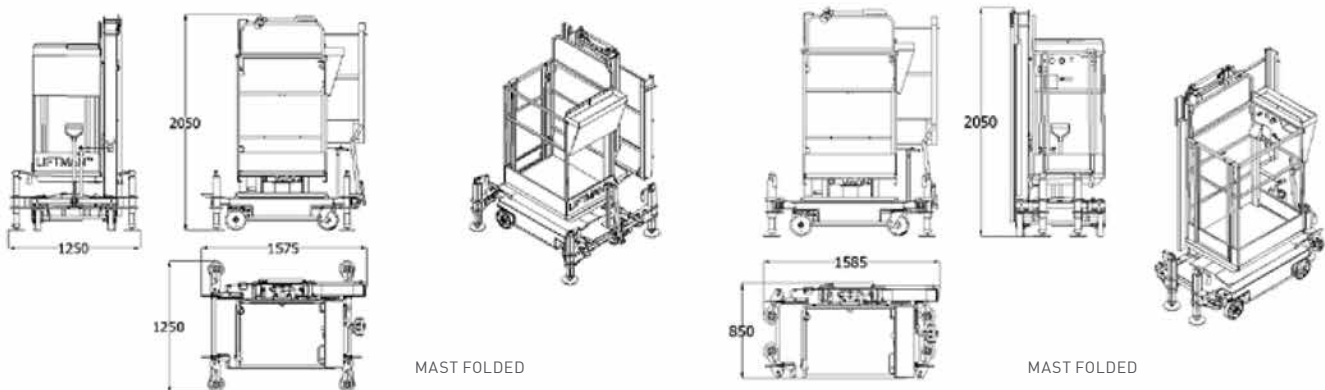
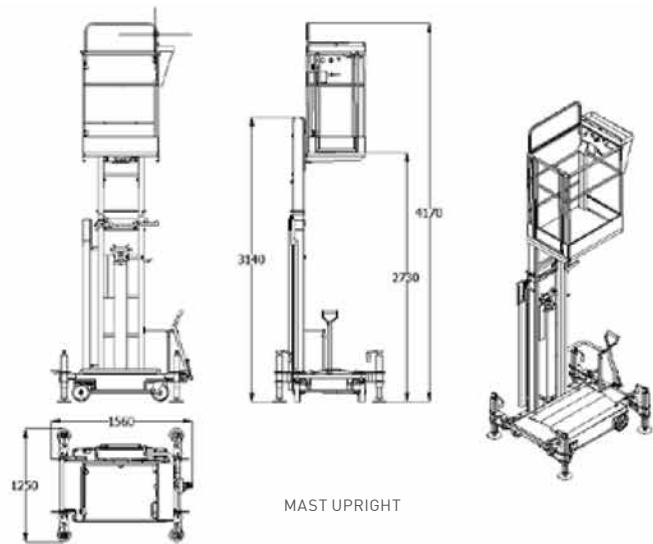

B3583-2