

for **LIVING**™
MC

Essex Gazebo

Model No. 088-1336-8

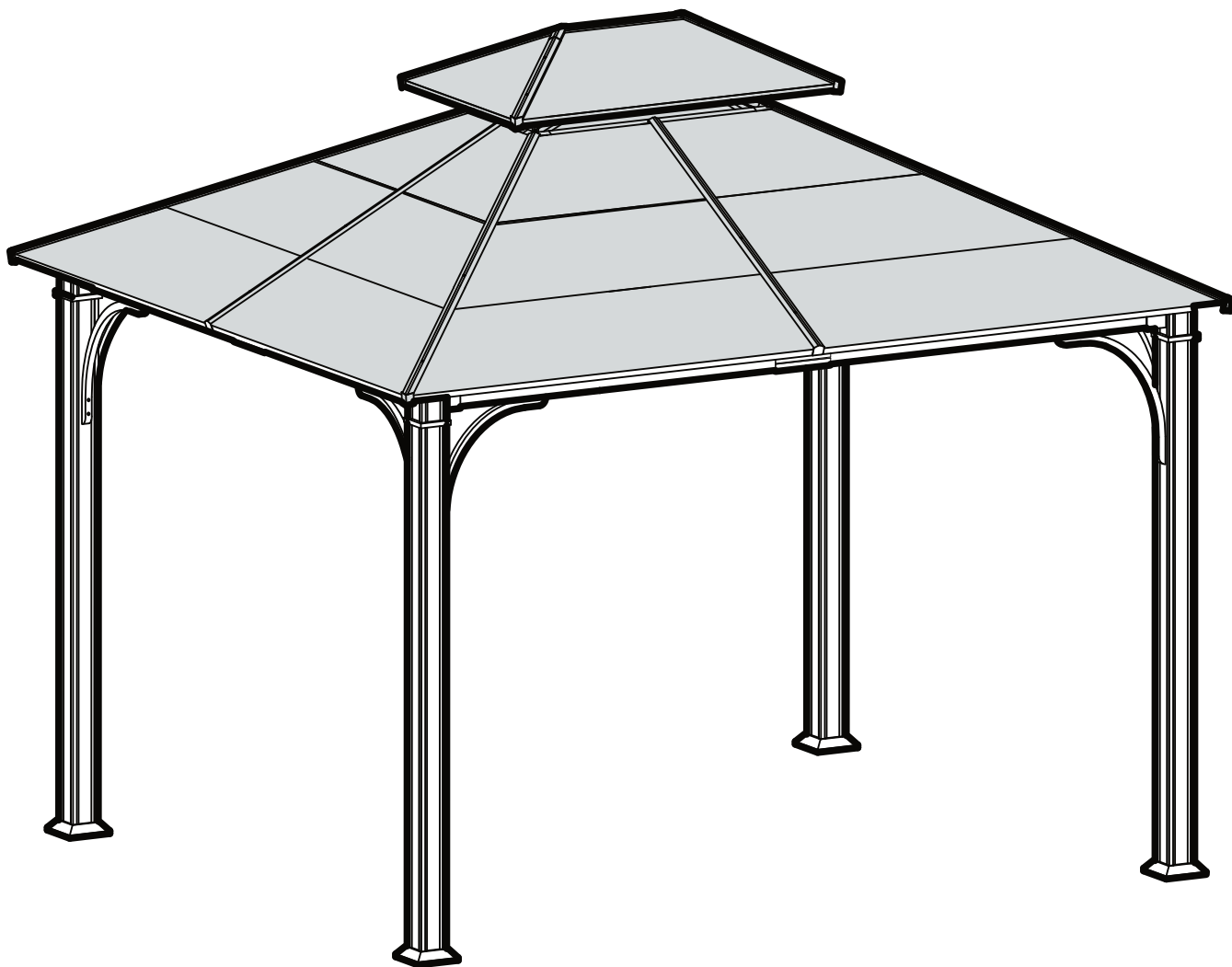

Assembly Instructions

Toll-free: 1-877-483-6759

IMPORTANT: Please read this manual carefully before beginning assembly of this product.
Keep this manual for future reference.

Table of contents	3
Important safety instructions	3
Package contents	4
Assembly	6
Cleaning and maintenance	20
Specifications	20
Warranty	21











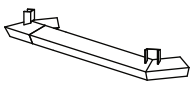

Warning! To reduce the risk of serious injury, read the following safety instructions before assembling and using the gazebo.

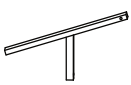





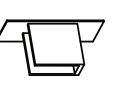
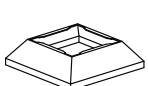
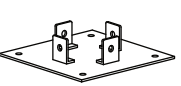

Caution! Always keep children under close supervision while they are near this product. Keep pets away while setting up the gazebo.

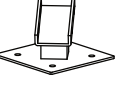
Caution! Check municipal by-laws prior to setting up the gazebo.

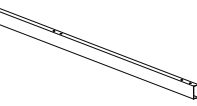
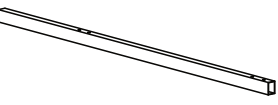
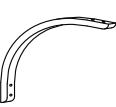



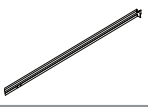



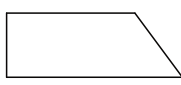
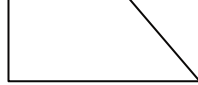
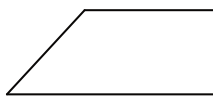
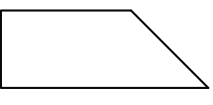
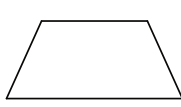
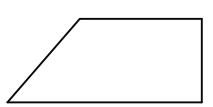
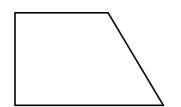
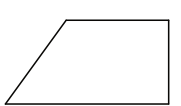
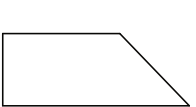
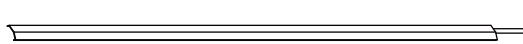
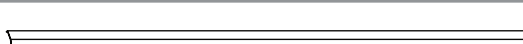

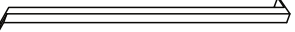
- This product is intended for domestic outdoor use i.e. decorative and sunshade purposes only.
- Always place and assemble the gazebo on flat horizontal ground.
- Consult with your local governing authority / local municipal codes regarding installation of temporary structures before assembly.
- Ensure there is enough clearance around the product. Before assembling the gazebo, make sure to leave a distance of not less than 6' (1.8 m) from any structures or obstructions, such as fences, garages, houses, overhanging branches, laundry lines, or electrical wires.
- Anchor the gazebo to the ground with stakes for added safety. Stakes are provided to secure the gazebo to the ground. If you wish to secure the gazebo to a concrete and wood surfaces, use anchors suited for these surfaces (anchors not included). Do not assemble the gazebo on sandy, muddy or loose soil, as stakes are not strong enough to anchor in these types of soil.
- If more than one gazebo is set up, keep a minimum distance of 10' (3 m) between the gazebos.
- Any assembly or maintenance of the gazebo must be carried out by adults only.
- Make sure there is sufficient manpower when assembling or moving the gazebo.
- Some parts may contain sharp edges. Wear protective gloves if necessary.
- Check all nuts and bolts periodically for tightness. If required, tighten them.
- Repairing and replacing parts should be done by a qualified technician.
- Always disassemble the gazebo before experiencing heavy wind conditions, as it is not designed to withstand harsh weather, including high wind, rain, and snow. In these conditions, it might tip over and could cause injury to bystanders.
- Do not hang any weights on the roof frame.
- Do not climb onto the roof of the gazebo. Doing so may cause the gazebo to fall down, possibly resulting in serious injury.
- During snow days, remove the snow at the top when the snow is thicker than 4" (10 cm).
- After a period of time, usually in 2–3 months, tighten all the bolts.
- After a few years, if the paint peels off, use paint of similar color. It is recommended to use outdoor paint.
- If the gazebo will not be used for a long period of time (e.g. during winter time), disassemble and store it in a clean, dry environment.
- Retain the original packaging to store the gazebo.

IMPORTANT: RETAIN FOR FUTURE REFERENCE, AND READ CAREFULLY.

A1	
Big top frame - 2	
B1	
Big top bar - 2	
C1	
Small top support beam - 4	
D1	
Small top connector - 1	
E1	
Hook - 1	
F1	
Top roof small panel - 2	
G1	
Top roof long panel - 2	
H1	
Small top cover - 4	
I1	
Small top roof cover - 1	
A4	
Post - 4	
C2	
Beam connector - 8	
D2	
Base cover - 4	
E2	
Base - 4	

F2	
Slanting bar connector - 4	
G2	
Upper beam connector - 4	
H2	
Lower beam connector - 4	
I2	
Short beam - 4	
J2	
Long beam - 4	
K2	
Arc support - 8	
L2a	
Long pipe 1 - 2	
L2b	
Long pipe 2 - 2	
M2a	
Short pipe 1 - 2	
M2b	
Short pipe 2 - 2	
A3	
Top slanting bar - 4	
B3	
Top beam - 4	
C3	
Long side left roof panel 1 - 2	

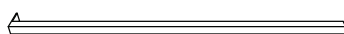
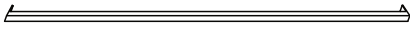
D3	
Long side right roof panel 1 - 2	
E3	
Long side left roof panel 2 - 2	
F3	
Long side right roof panel 2 - 2	
G3	
Long side left roof panel 3 - 2	
H3	
Long side right roof panel 3 - 2	
I3	
Short side roof panel 1 - 2	
J3	
Short side left roof panel 2 - 2	
K3	
Short side right roof panel 2 - 2	
L3	
Short side left roof panel 3 - 2	
M3	
Short side right roof panel 3 - 2	
N3	
Big roof panel cover (corner) - 4	
O3	
Big roof panel cover (middle) - 4	

W1	
Big roof top beam (short side) (1) - 2	
W2	
Big roof top beam (short side) (2) - 2	
W3	
Big roof top beam (short side) (3) - 2	
W4	
Big roof top beam (short side) (4) - 2	
W5	
Big roof top beam (short side) (5) - 2	
W6	
Big roof top beam (short side) (6) - 2	
X1	
Big roof top beam (long side) (1) - 2	
X2	
Big roof top beam (long side) (2) - 2	
X3	
Big roof top beam (long side) (3) - 2	
X4	
Big roof top beam (long side) (4) - 2	
X5	
Big roof top beam (long side) (5) - 2	
X6	
Big roof top beam (long side) (6) - 2	

AA

Screw (1/4" - 20 x 0.6) - 140 + 7 spare

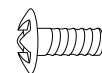

BB

Flat washer (1/4") - 330 + 17 spare



CC

Screw (1/4" - 20 x 2.125) - 22 + 2 spare



DD

Nut (1/4") - 36 + 3 spare



EE

Screw (1/4" - 20 x 1.4) - 24 + 2 spare

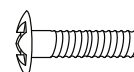

FF

Bolt (1/4" - 20 x 0.6) - 80 + 4 spare



GG

Bolt (1/4" - 20 x 2.6) - 16 + 2 spare

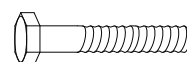

HH

Bolt (1/4" - 20 x 1.75) - 32 + 2 spare

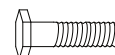

II

Stake (5/16 x 10.24") - 16

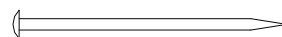

Z

Wrench (1/4") - 2

**Caution!**

- Proper placement of the gazebo is essential. Do not place the gazebo underneath electrical lines.
- Keep children under close supervision while they are near this product. This product contains small parts which can be swallowed by children.
- Keep fingers away from places where they can be pinched or trapped.
- Do not attempt to assemble the gazebo if any part is missing.

**Let us help you!**

DO NOT RETURN YOUR PRODUCT TO THE STORE. CALL US FIRST!
1-877-483-6759

If you have questions regarding your product, require warranty assistance, or have damaged or missing parts, please call our customer service toll-free helpline. Contact us for assistance; we're here to help.

IMPORTANT: Please read and understand this manual before any assembly. Before beginning the assembly of the product, make sure all parts are available. Compare parts with package contents list. If any part is missing, or if you have any questions, contact the service center at 1-877-483-6759 (toll-free).

Take all parts from the box and position them on a clean floor. Remove all packing materials and place them back into the box. Do not dispose of the packing materials until assembly is complete. Read each step carefully before beginning any assembly and make sure you understand each step.

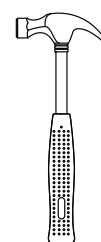
Needed for assembly:

Hammer



Screwdriver

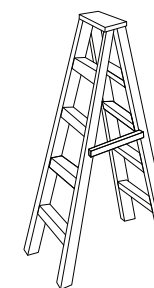

Ladders (6' / 2 m tall)



5 people

Note: When using screws and nuts to assemble the product, always use a flat washer between the frames and the screw and/or nut. This will protect the parts from wear and tear.

Step 1

Requires **A1, B1, AA, BB**

Attach the big top frame (A1) to the big top bar (B1) using screw (AA) and flat washer (BB).

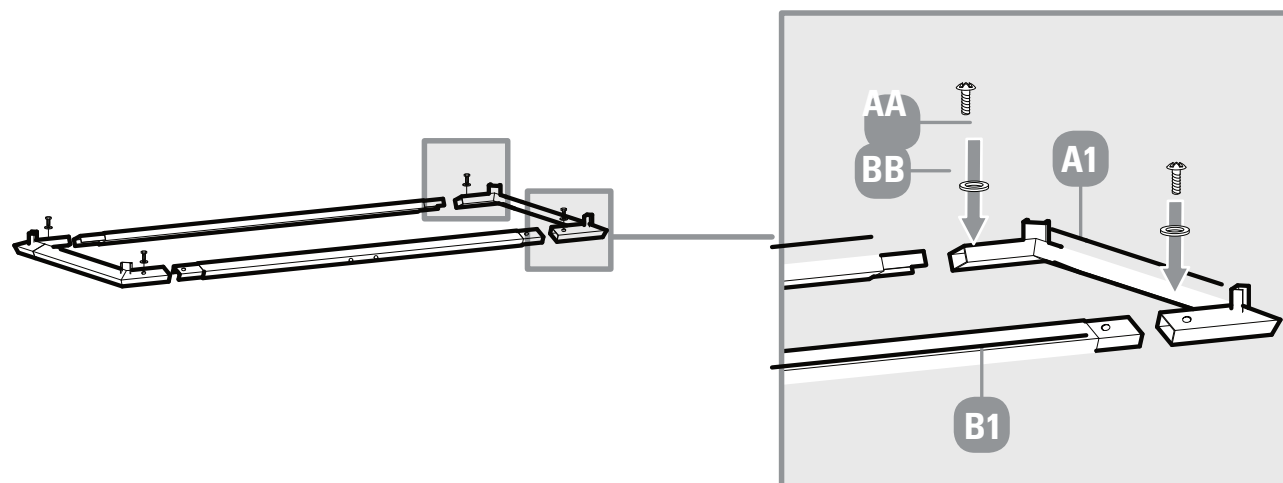

Step 2

Requires **C1, A1, AA, BB**

Attach one end of the small top support beam (C1) to the connector of the big top frame (A1) using screw (AA) and flat washer (BB).

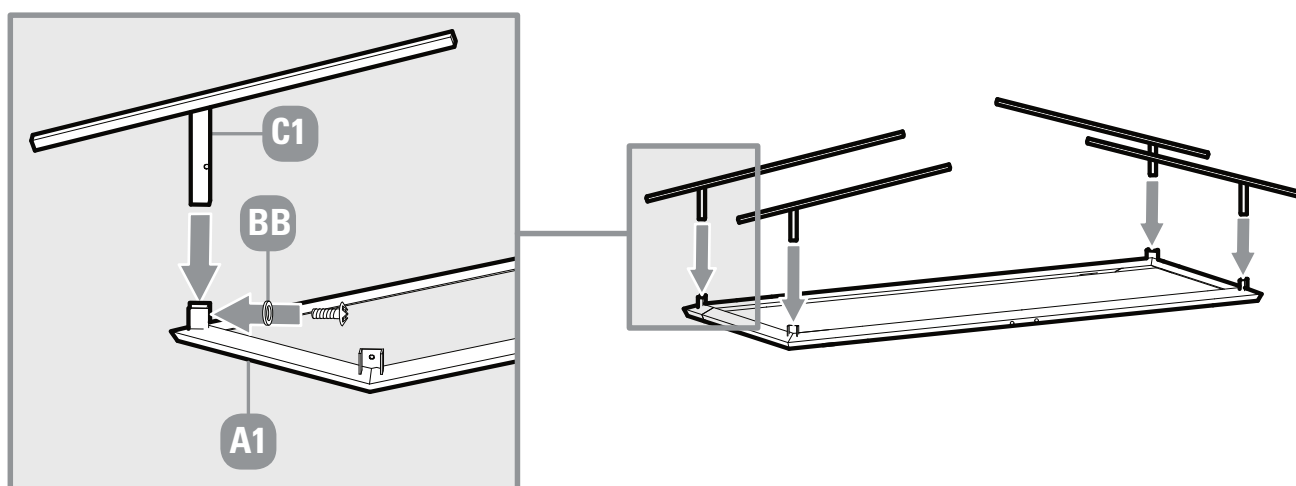

Step 3

Requires **C1, D1, BB, CC, DD**

Attach the other end of the small top support beam (C1) to the small top connector (D1) using nut (DD), flat washer (BB) and screw (CC).

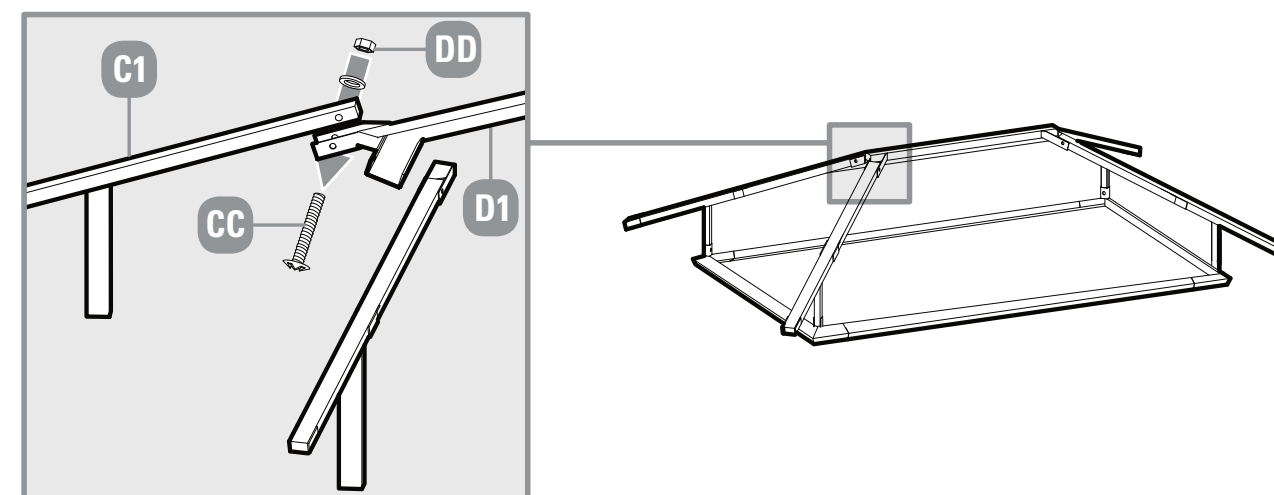
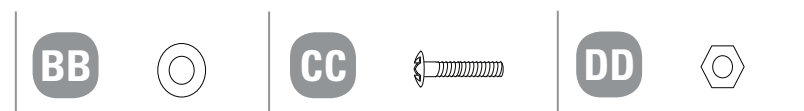

Step 4

Requires **D1, E1**

Insert and screw the hook (E1) tightly into the corresponding hole on the small top connector (D1).

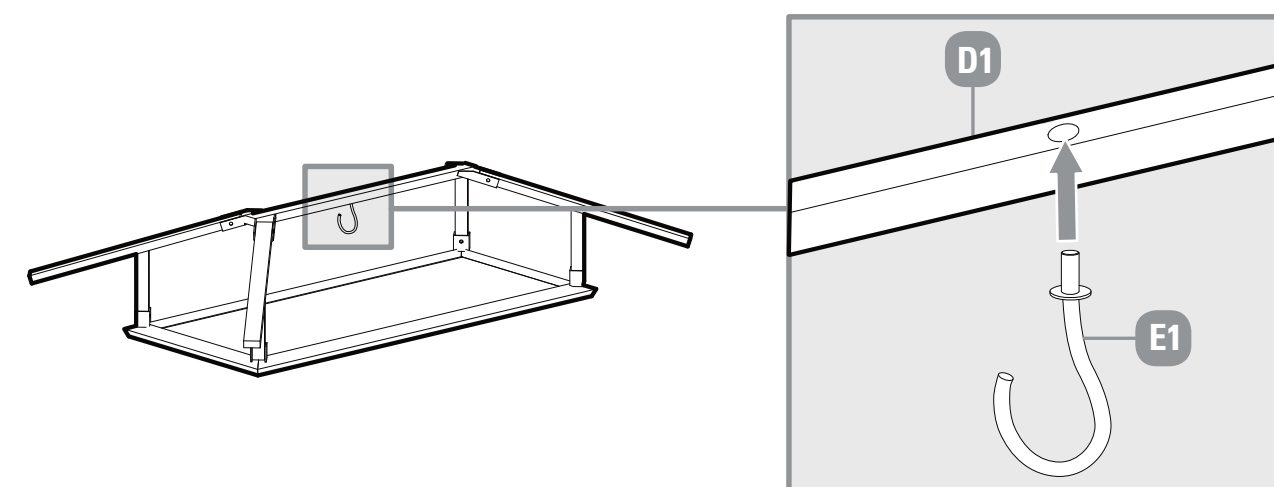

Step 5Requires **A4, C2, BB, FF**

Attach the beam connector (C2) to the post (A4) using bolt (FF) and washer (BB).

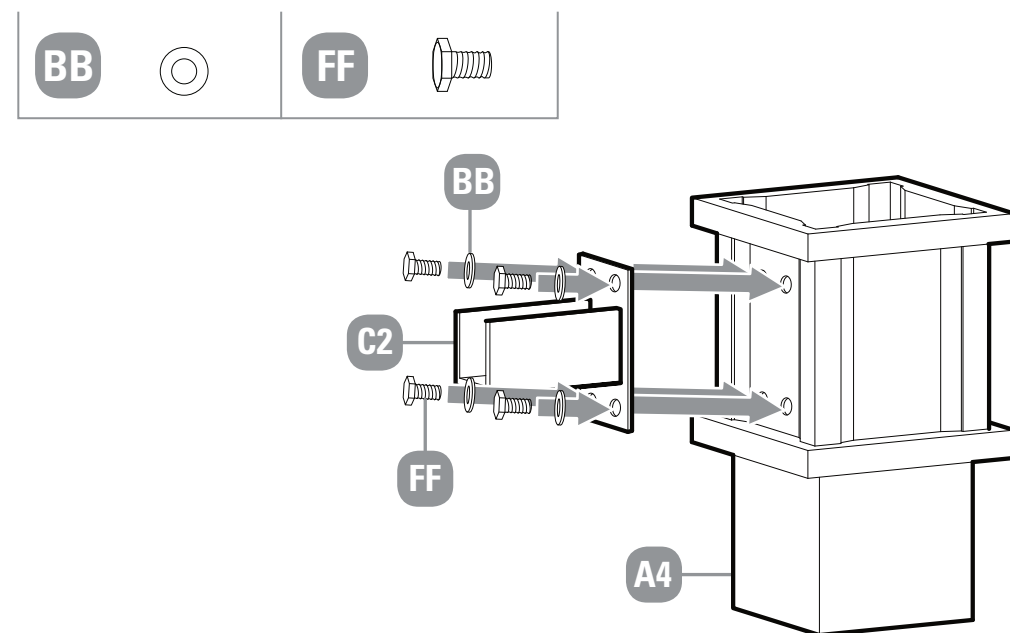
**Step 6**Requires **A4, F2, BB, FF**

Attach the slanting bar connector (F2) to the post (A4) using bolt (FF) and washer (BB).

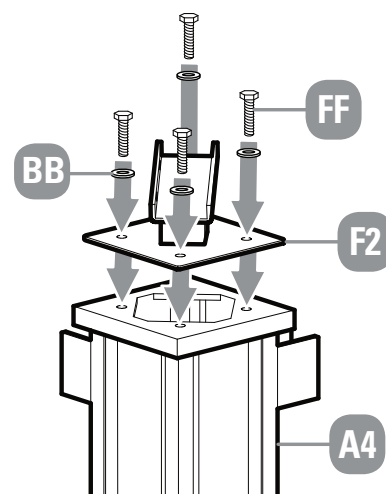
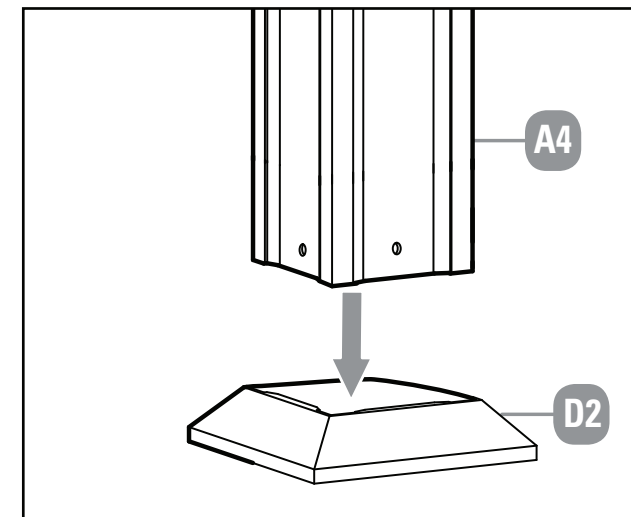
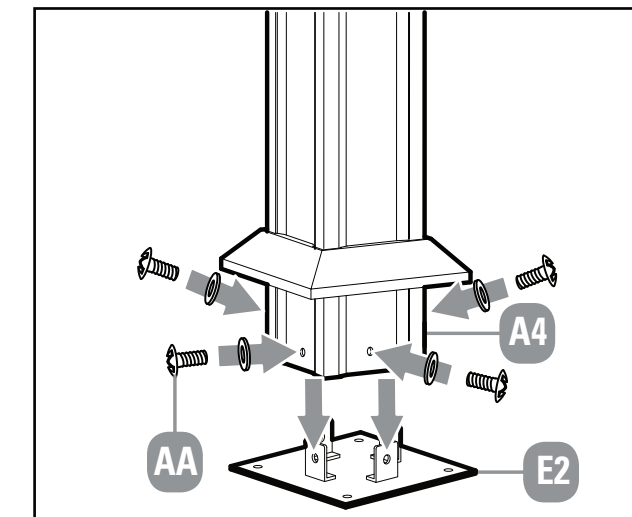
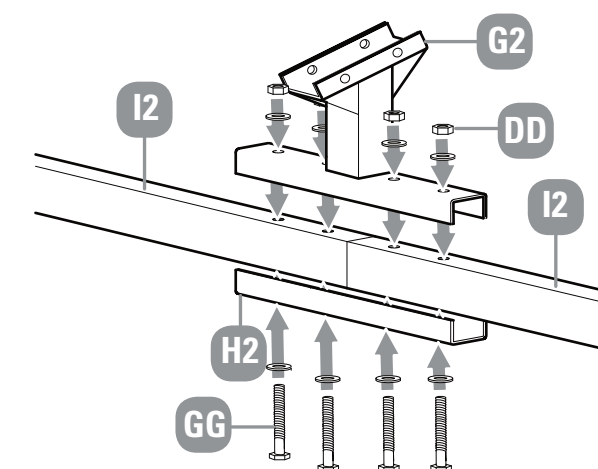
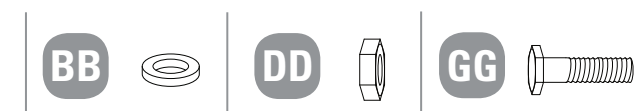
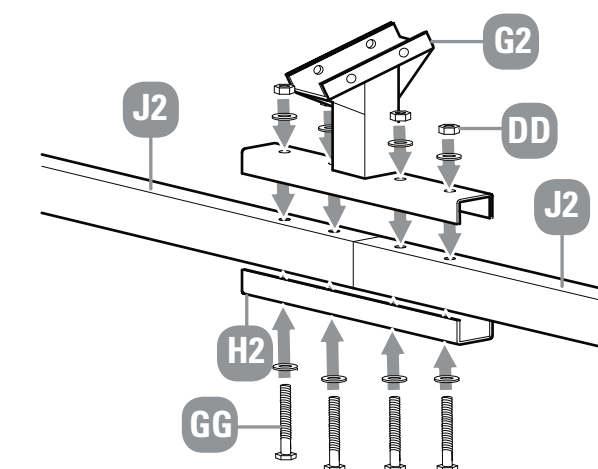
**Step 7**Requires **A4, D2, E2, AA, BB****(7a)** Insert the post (A4) into base cover (D2).**(7b)** Attach the base (E2) to the post (A4) using screw (AA) and washer (BB).**Step 8**Requires **G2, H2, I2, J2, BB, DD, GG****(8a)** Attach beam connector (G2), (H2), short beam (I2) using bolt (GG), washer (BB), and nut (DD).**(8b)** Attach beam connector (G2), (H2), long beam (J2) using bolt (GG), washer (BB), and nut (DD).

Step 9Requires **C2, I2 J2, BB, FF**

Connect the other ends of long beam (I2) and short beam (J2) to the beam connector (C2) using screw (FF) and washer (BB).

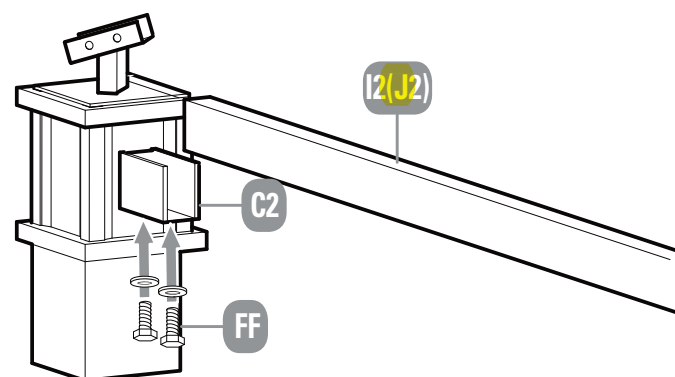
**Step 10**Requires **A4, K2, BB, HH**

Attach the arc support (K2) to the post (A4) and short/long beams. Secure them using bolt (HH) and washer (BB).

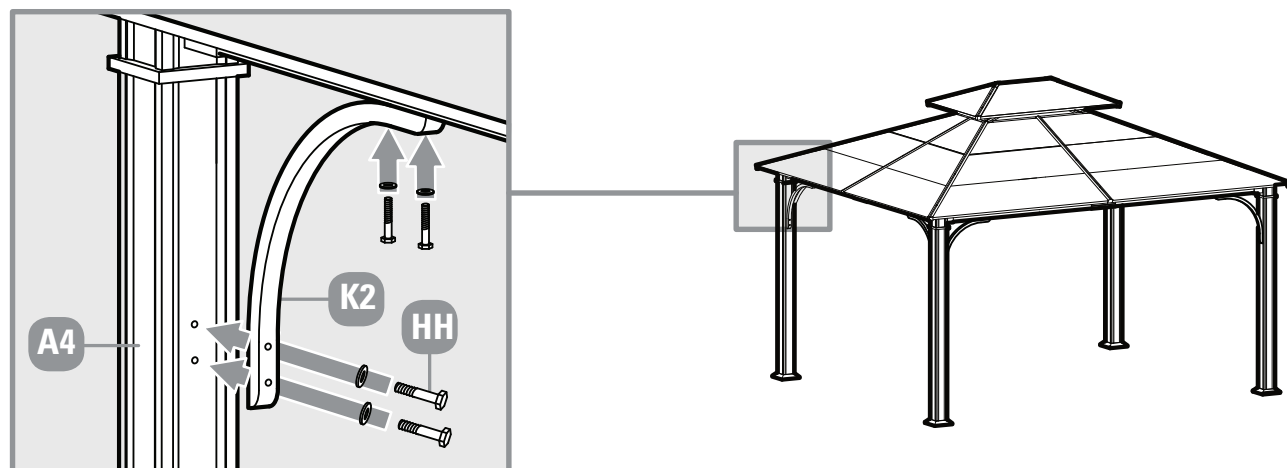
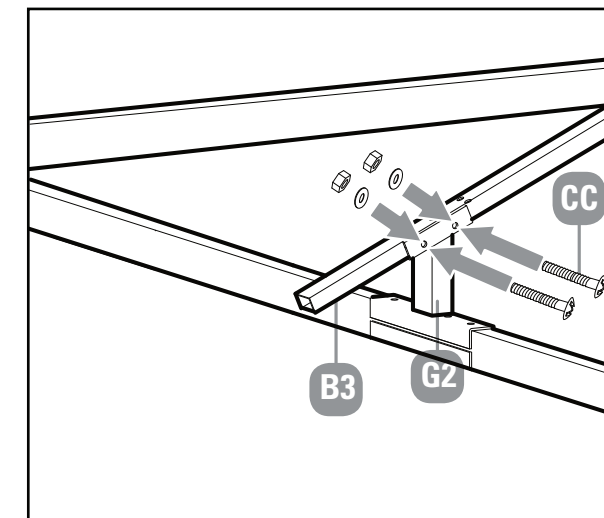
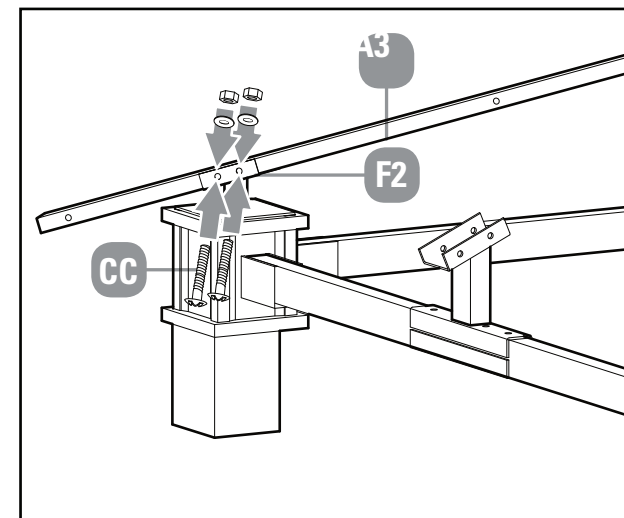
**Step 11**Requires **A3, B3, F2, G2, BB, CC, DD****(11a)** Attach one end of the top slanting bar (A3) to the slanting bar connector (F2) using screw (CC), washer (BB) and nut (DD).**(11b)** Attach one end of the top beam (B3) to the upper beam connector (G2) using screw (CC), washer (BB) and nut (DD).**Step 12**Requires **A1, A3, B1, B3, BB, FF**

Attach top slanting bar (A3) and big top frame (A1), top beam (B3) and big top frame (A1) / big top bar (B1) using bolt (FF) and washer (BB).

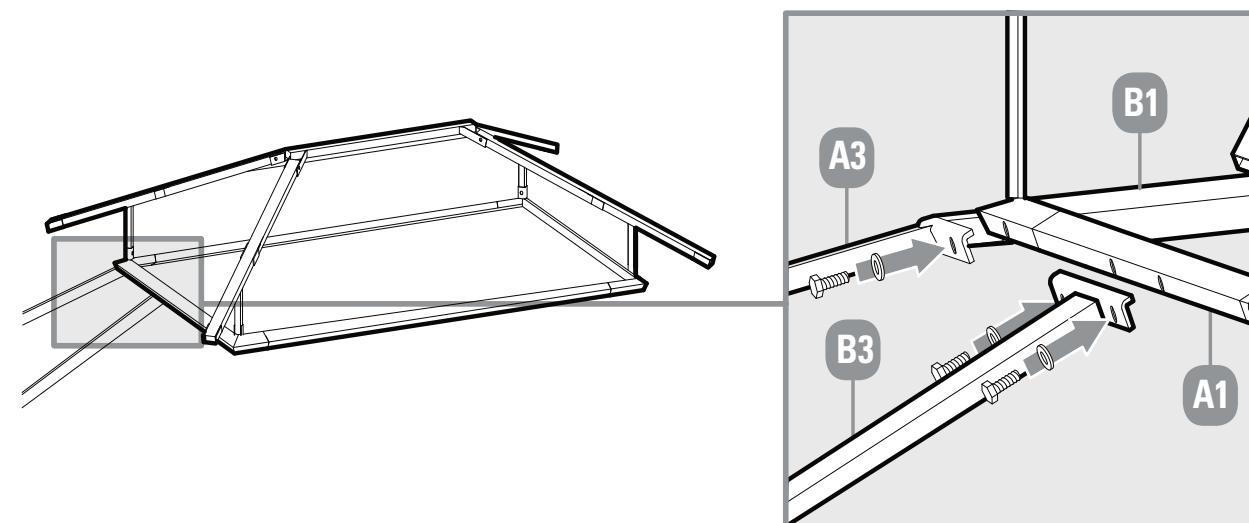

Step 13Requires **F1, G1, AA, BB**

Place the top roof small panel (F1) and the top roof long panel (G1) onto the small top support beam and attach using screw (AA) and washer (BB).

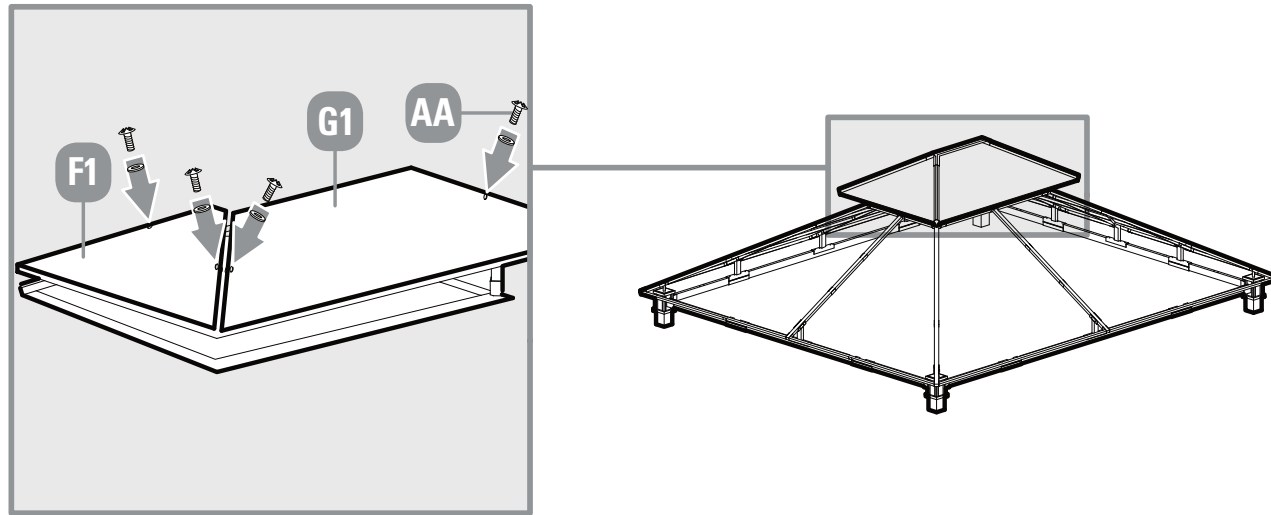
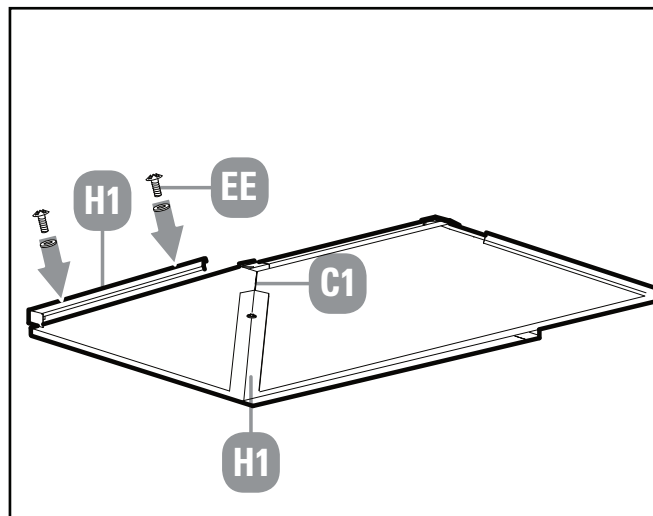
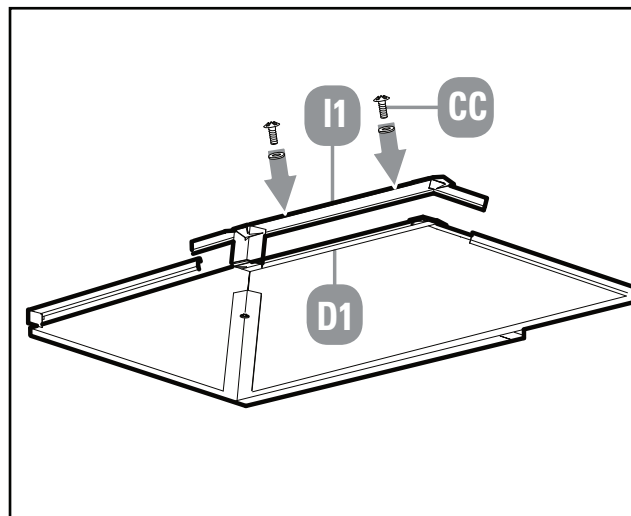
**Step 14**Requires **C1, D1, H1, I1, BB, EE****(14a)** Place the small top covers (H1) onto the small top support beam (C1) and attach using two screws (EE) and washers (BB).**(14b)** Place the small top roof cover (I1) onto the small top connector (D1) and attach using two screws (CC) and washers (BB).**Step 15**Requires **W1, W2, W3, W4, W5, W6, AA, BB**

Attach the big roof top beams (short side) (W1, W2, W3, W4, W5, W6) to the top slanting bar and the top beam using screw (AA) and washer (BB).

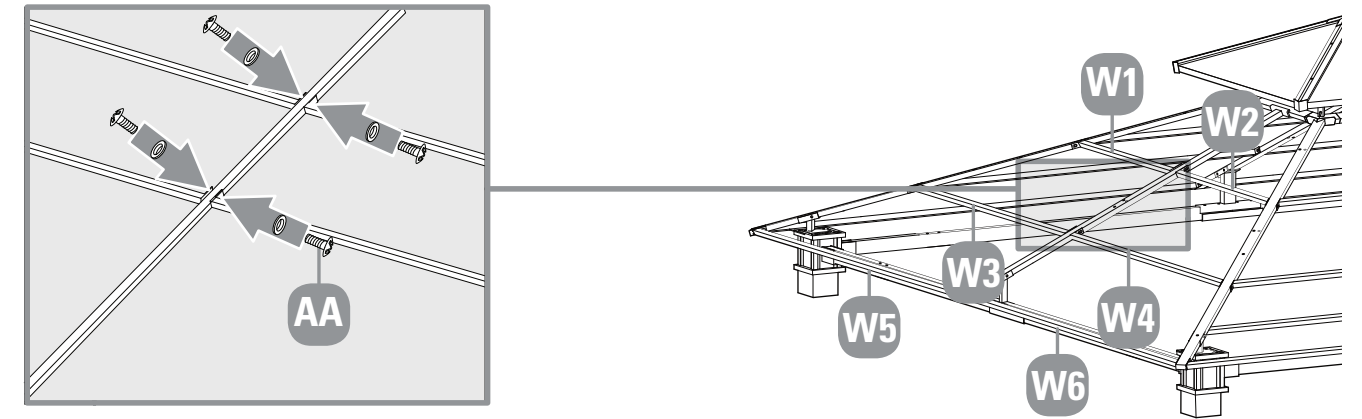
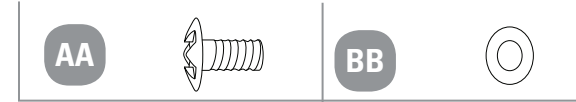
**Step 16**Requires **X1, X2, X3, X4, X5, X6, AA, BB**

Attach the big roof top beams (long side) (X1, X2, X3, X4, X5, X6) to the top slanting bar and the top beam using screw (AA) and washer (BB).

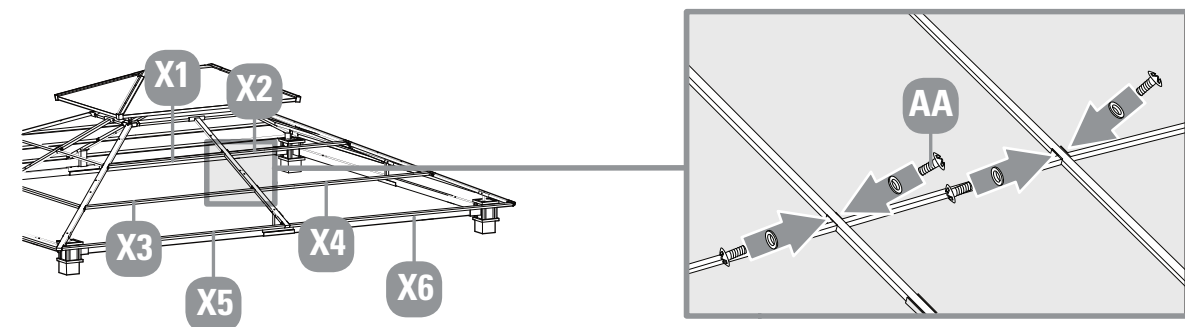

Step 17Requires **B3, L2a, L2b, AA, BB**

Attach one end of the long pipes (L2a, L2b) to the top beam (B3) using screw (AA) and washer (BB).

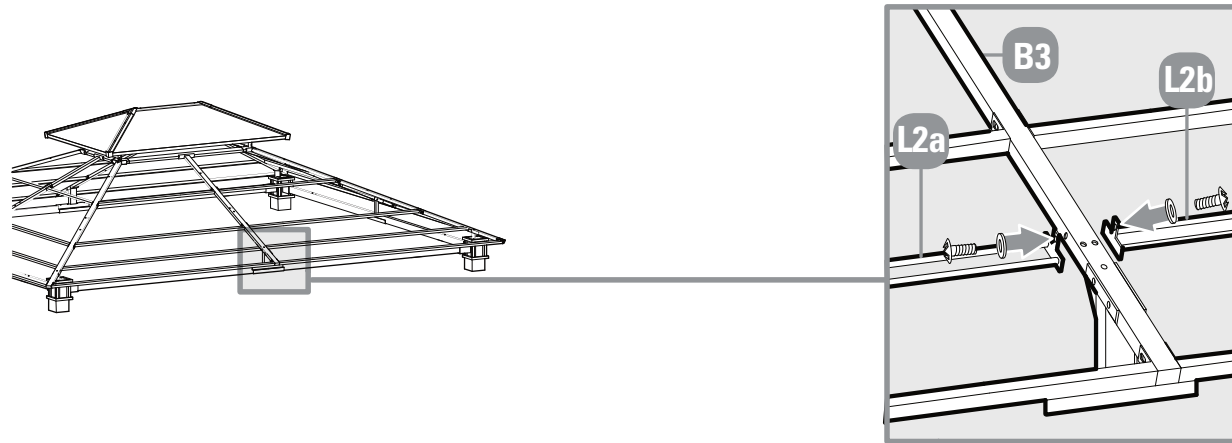
**Step 18**Requires **M2a, M2b**

Repeat the same procedure for connecting short pipes (M2a, M2b) to the top beam.

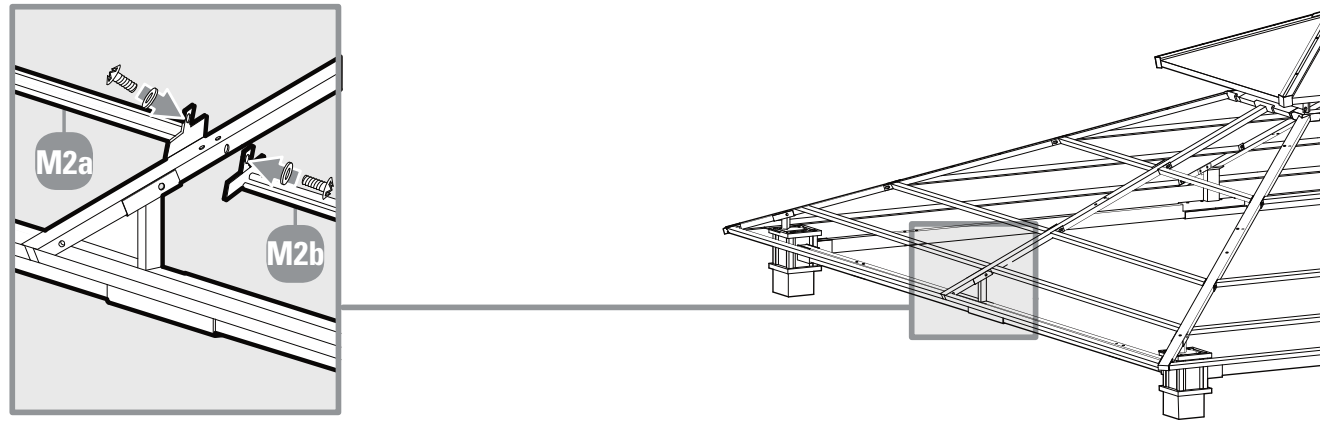
**Step 19**Requires **A3, L2a, L2b, AA, BB**

Attach the other end of the long pipes (L2a, L2b) to the top slanting bar (A3) using screw (AA) and washer (BB).

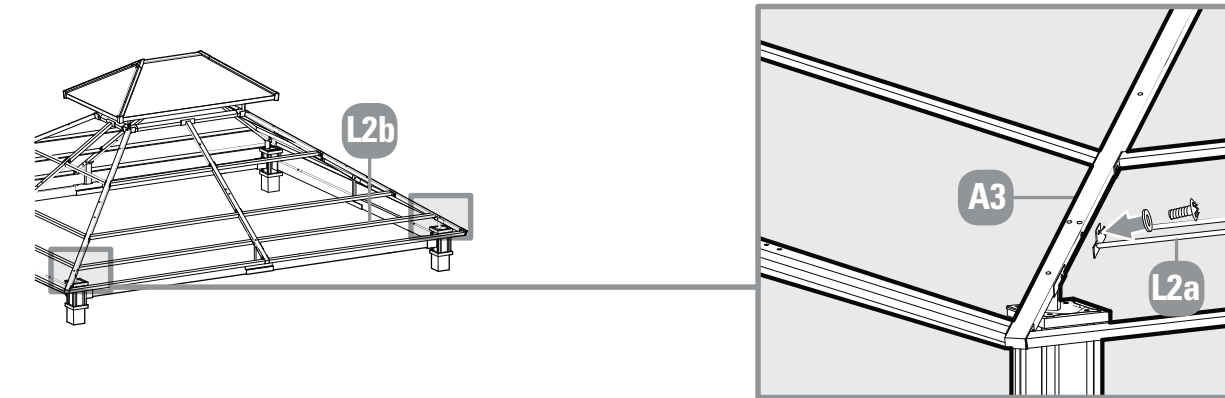
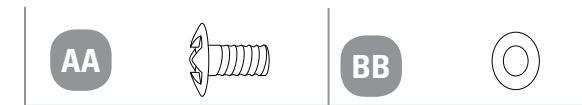
**Step 20**Requires **M2a, M2b**

Repeat the above procedure for connecting short pipes (M2a, M2b) to the top slanting bar.

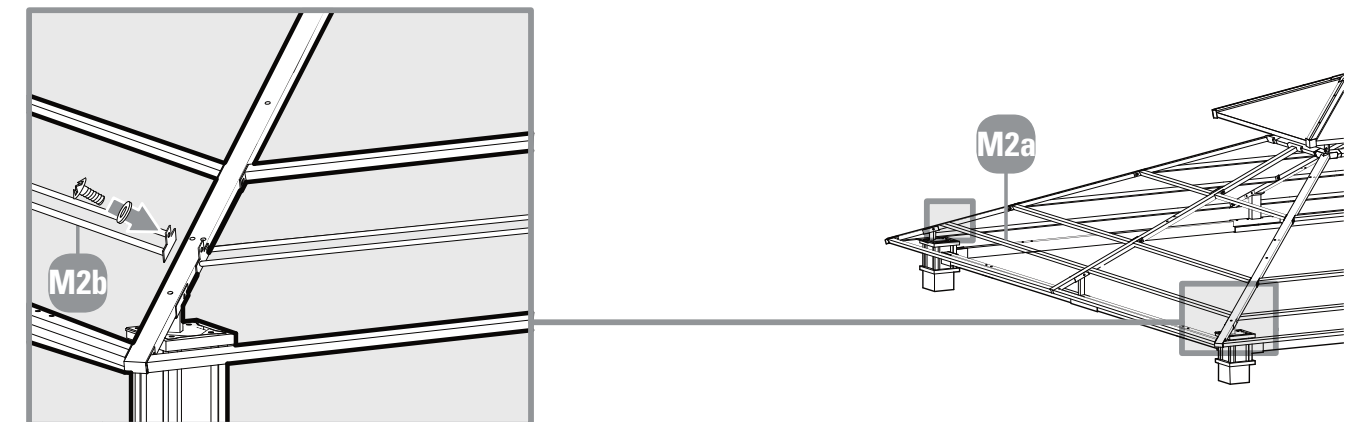

Step 21Requires **C3, D3, E3, F3, G3, H3, AA, BB**

Place the long side roof panels (C3, D3, E3, F3, G3, H3) onto the big top frame from upper end to lower end and attach using two screws (AA) and two washers (BB) on each panel.

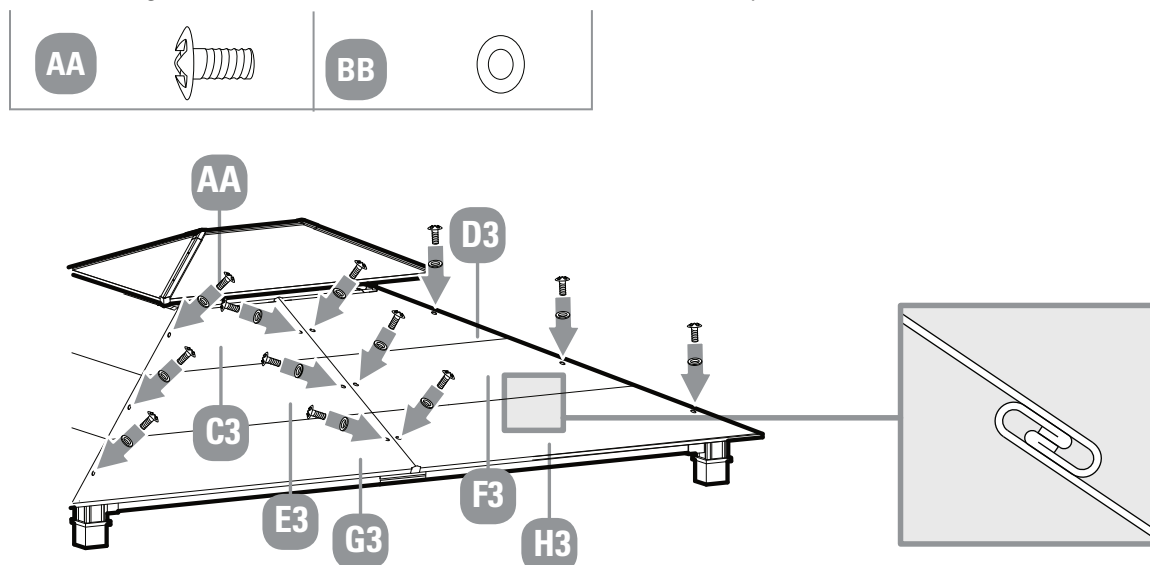
**Step 22**Requires **I3, J3, K3, L3, M3, AA, BB**

Place the short side roof panels (I3, J3, K3, L3, M3) onto the big top frame from upper end to lower end and attach using two screws (AA) and two washers (BB) on each panel.

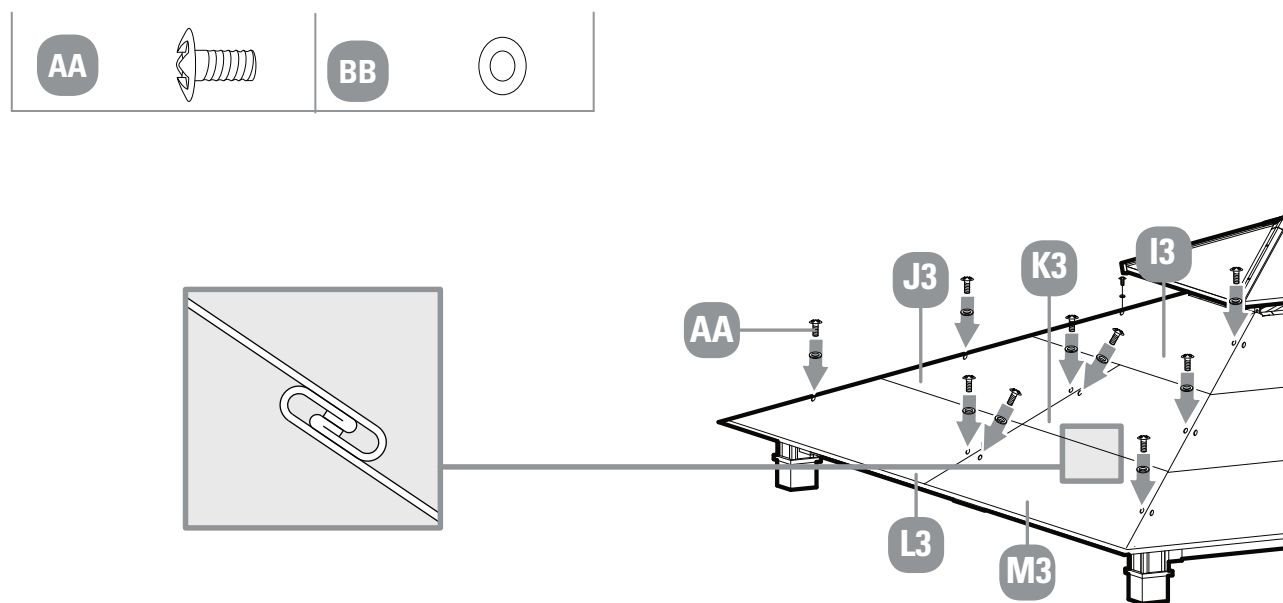
**Step 23**Requires **C1, N3**

Insert the big roof panel cover (corner) (N3) into the hole of the small top support beam (C1).

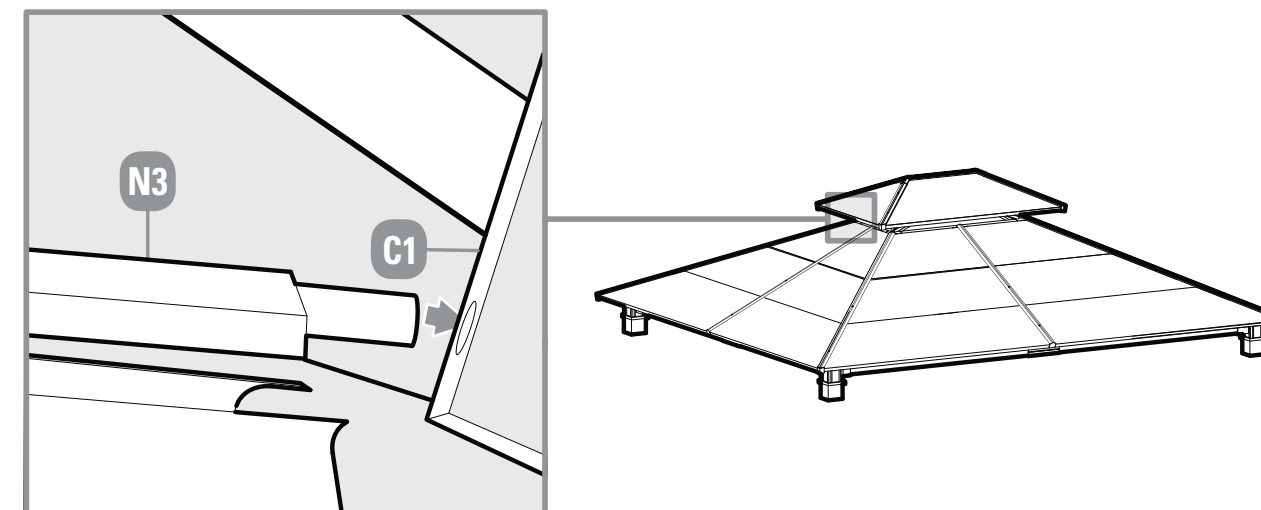
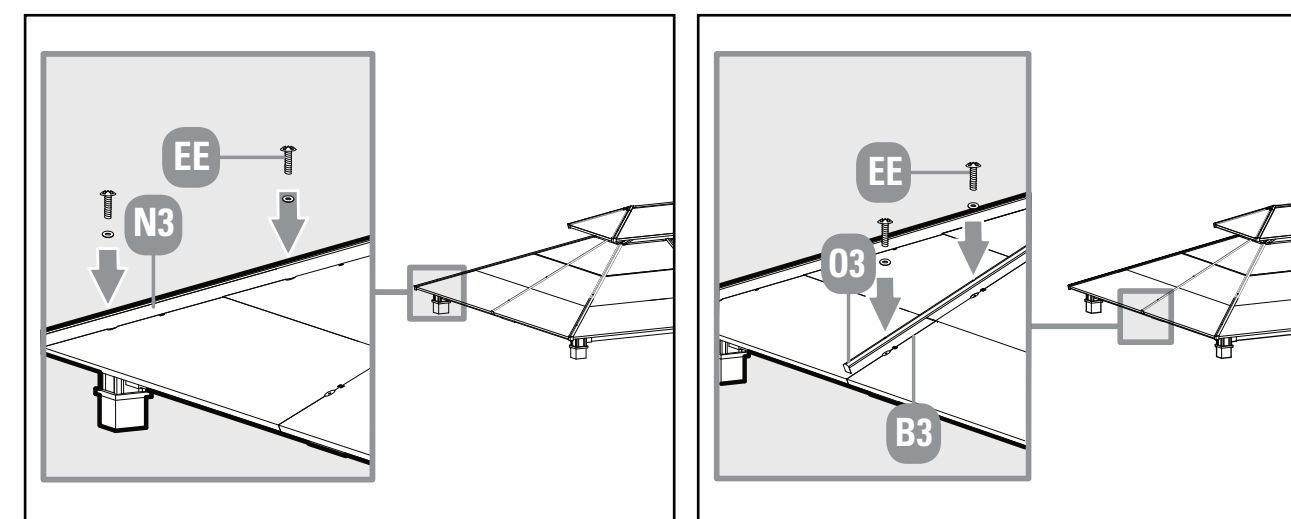
**Step 24**Requires **A3, B3, N3, O3, BB, EE****(24a)** Attach the big roof panel cover (corner) (N3) to the top slanting bar (A3) using screw (EE) and washer (BB).**(24b)** Attach the big roof panel cover (middle) (O3) to the top beam (B3) using screw (EE) and washer (BB).

Step 25Requires **D2, E2, II**

(25a) Move and hold base cover (D2) upward so the base (E2) can be anchored to the ground using the stakes (II). Then put down the base cover. Repeat this step until all four posts are anchored.

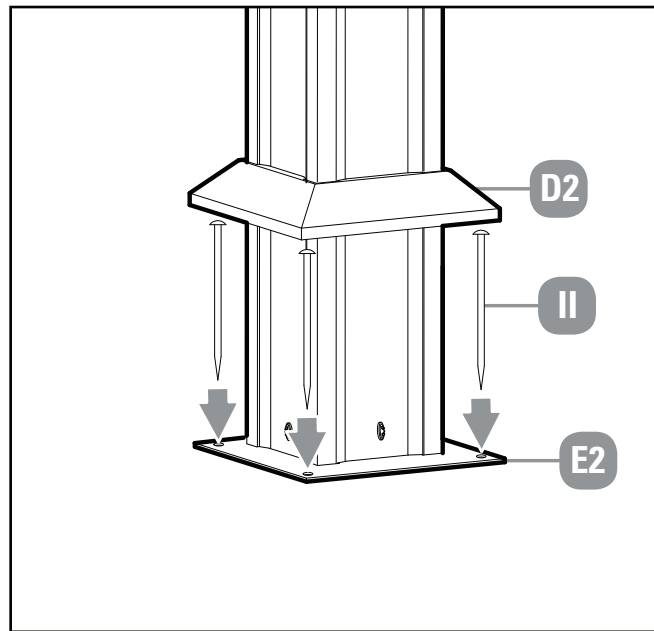

(25b) The gazebo is ready for use.

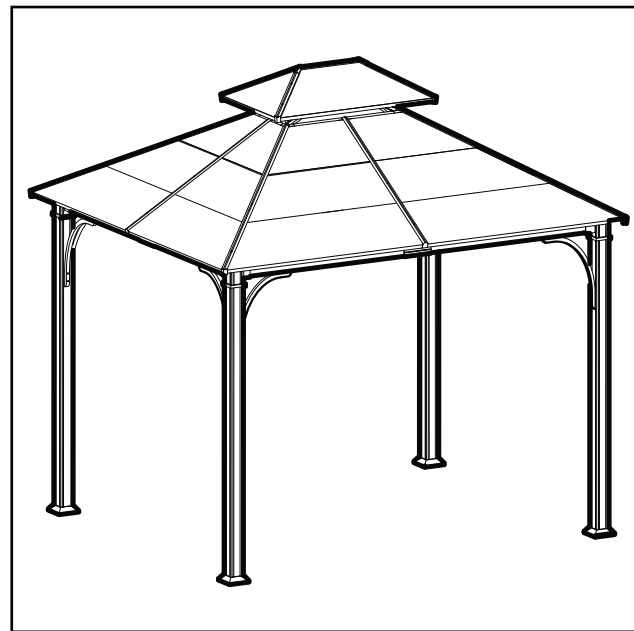
**Caution!**

- Check all screws and nuts periodically for tightness. Tighten them if required.
- Disassemble the gazebo in the reverse order of the assembly steps. Always disassemble the gazebo completely. A partially disassembled gazebo is not stable enough to resist wind and bad weather, and therefore can be damaged and/or cause damage.

- Do not use bleach, acid, or other abrasive cleaners on the roof panels or beams.
- Steel components of garden accessories and furniture are coated with rust-inhibiting paint. However, due to the nature of steel, surface oxidation (rusting) will occur if this protective coating is scratched. This is a natural process. To minimize this condition, it is recommended that care be taken when assembling and handling the product, in order to prevent the paint from being scratched. Surface rust can be removed easily by applying a little common cooking oil. If surface oxidation (rusting) occurs and no measures are taken to correct it, the oxidation may start dripping onto the assembly surface, which may cause rough stains that could be difficult to remove.

Dimensions (L x W x H)

144 x 121 x 121"

366 x 308 x 307 cm

Product weight

346 lb

157 kg

This For Living™ product carries a three (3) year limited warranty against defects in workmanship and materials. Trileaf Distribution agrees to replace the defective product free of charge within the stated warranty period, when returned by the original purchaser with proof of purchase. This product is not guaranteed against wear or breakage due to misuse and/or abuse.